

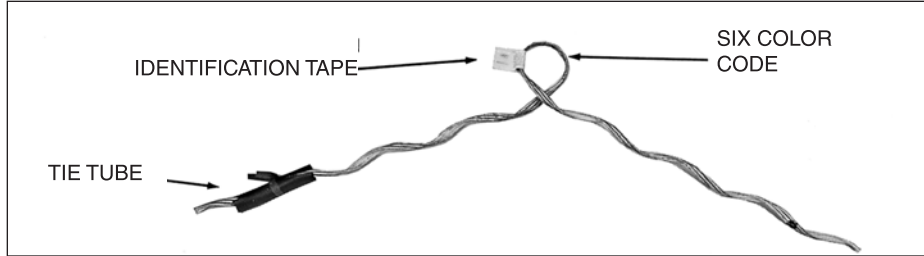

Spool Tie

NOMENCLATURE

RUS Accepted



Tie Assembly: A Spool Tie Assembly consists of one metal tie component plus tie tube.

Applied Length: Describes length of tie after installation, plus assists in product identification.

Tie Tube: Each Spool Tie is supplied with an elastomeric tie tube designed for abrasion protection with bare conductors.

Color Code: Identifies proper conductor size, corresponding to tabular information appearing in this section.

Identification Tape: Lists catalog numbers, proper insulator type, and nominal conductor sizes.

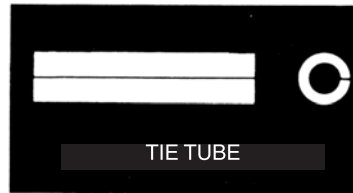

GENERAL RECOMMENDATIONS

The Spool Tie is intended for use on aluminum based conductors with diameters from .190" to .968".

Mechanical Strength: The Spool Tie is designed to provide superior mechanical strength and resiliency during conductor motion and cyclic loading conditions. Longitudinal holding strengths consistently exceed the requirements of the National Electric Safety Code. **TM-168E** covers the mechanical testing of the Spool Tie and is available upon request.

Interchangeable Neck-Style Insulators: Spool Ties listed in this section are designed to be applied to ANSI Class 53-1, 53-2, and 53-3 spool insulators which have 1-3/4" neck diameters. Consult PLP for specifics. "F" neck size Side Ties can be used for application on ANSI Class 53-4 and 53-5 which have 2-7/8" neck diameters.

The RIV/TVI characteristics of Spool Ties are equivalent to those of a well made hand tie as originally installed. The precontoured loop and formed legs of the Spool Tie assure continued fit, which provide better RIV/TVI performance than a loosened tie wire.

To insure proper fit and service life of the Spool Tie, it is recommended only spool insulators with uniform dimensions, as described by the latest (C29.3) ANSI standards be used. A partial listing of acceptable insulators appears on the last page of this section. Consult PLP for applications on non-listed or non-standard insulators.

Vibration Dampers: The Spool Tie is designed to outperform the hand tie during conductor motion activity, such as aeolian vibration and galloping. However, on some lines, the use of dampers may be necessary to prevent damage. Utilities that have experienced conductor motion or expect to, should consider adding dampers. Consult PLP® for general guidelines and advice concerning conductor motion and dampers. Also consult the Motion Control catalog section.

Each Spool Tie is supplied with an elastomeric tie tube designed to minimize abrasion to bare conductors and insulators. For application on jacketed conductors, the tube may be discarded. Spool Ties can also be applied to bare conductor without the tube where desired, although consideration of abrasion should be given.

Spool Tie

INSTALLATION GUIDELINES

- 1. Insulator Mounting:** When installing a Spool Tie, the spool insulator may be mounted either horizontally or vertically. Whatever the construction style, the conductor should be positioned so it will bear, as much as possible, into the insulator. During vertical mounted installations, the insulator should be removed from the rack or clevis so the conductor may be positioned inside the insulator. However, when running angles turn *into* the pole, the conductor should be placed on the *outside* of the insulator so the conductor bears against the spool.

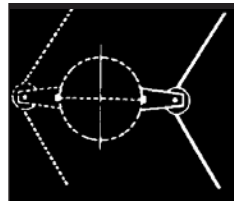
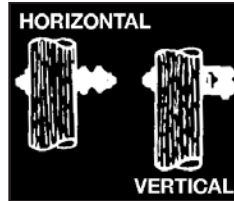

- 2. Line Angles - General Guidelines:** On horizontally-mounted insulators, Spool Ties can normally accommodate line angles up to 10° . On vertically-mounted insulators, line angles up to 40° can normally be achieved. In all cases the conductor should rest in the preferred insulator groove, independently of the tie, so the tie is not required to force the conductor to remain in that groove. The largest practical angle a tie can accommodate depends upon limiting factors such as conductor size, tension, span lengths, sag angles, insulator style and orientation, etc. Consult PLP[®] for further guidance on line angle issues.
- 3. Tapping:** Taps should not be made directly over the legs or loop of the Spool Tie.
- 4. Conductor Compatibility:** Spool Ties should be used only on the size, type, and lay direction for which they are designed. When using conductors not mentioned in this catalog section, consult PLP.
- 5.** During installation and at all times, care should be taken to avoid gouging or damaging the protective coating of the Spool Tie or the conductor.
- 6.** Spool Ties should not be used as tools; i.e., come-alongs, pulling-in grips, etc.
- 7.** Consult the Spool Tie Application Procedure for additional installation information.
- 8.** When in doubt about usage of Spool Ties, consult your PLP representative or Preformed Line Products.

SAFETY CONSIDERATIONS

- 1.** This product is intended for a single (one-time) use and for the specified application. CAUTION: DO NOT REUSE OR MODIFY THIS PRODUCT UNDER ANY CIRCUMSTANCES.
- 2.** This product is intended for use by trained craftspeople only. This product SHOULD NOT BE USED by anyone who is not familiar with and trained in the use of it.
- 3.** When working in the area of energized lines with this product, EXTRA CARE should be taken to prevent accidental electrical contact.
- 4.** For PROPER PERFORMANCE AND PERSONAL SAFETY be sure to select the proper size PREFORMED[™] Spool Tie before application.
- 5.** PREFORMED Spool Ties are precision devices. To insure proper performance, they should be stored in cartons under cover and handled carefully.



Spool Tie

For use on:
ACAR, All-Aluminum
ACSR, Aluminum Alloy
AWAC, Compacted ACSR

Spool Insulator

ANSI 53-1
ANSI 53-2 **1-3/4" Neck Diam.**
ANSI 53-3

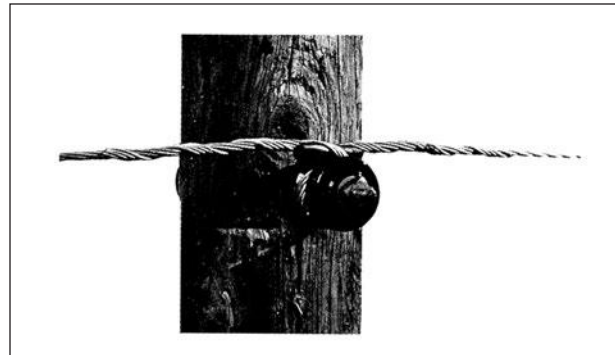

Catalog Number	Diameter Range (Inches)		Nominal Conductor Size		Units Per Carton	Wt./Lbs.	Applied Length (Inches)	Color Code
	Min.	Max.	Bare Conductor	Plastic Jacketed Conductor				
SPL-1352-P	.245	.277	#4, 6/1, 7/1 #4, 7W Alum. Alloy	#6, 7W, 2/64s #6, Solid, 3/64s #6, 6/1, 2/64s	100	16	19	Orange
SPL-1353-P	.278	.315	#3, 7W Alum. Alloy #2, 7W All Alum.	#6, 6/1, 3/64s #4, Solid, 3/64s #4, 6/1, 2/64s	100	17	21	Purple
SPL-1354-P	.316	.357	#2, 6/1, 7/1 #2, 7W Alum. Alloy #1, 6/1	#2, 7W, 3/64s #4, 6/1, 7/1, 3/64s	100	23	24	Red
SPL-1355-P	.358	.405	1/0, 7W All Alum. 1/0, 6/1 1/0, 7W Alum. Alloy	#3, 7W, 4/64s #2, 7W, 3/64s #4, 7W, 5/65s	100	24	26	Yellow

Right-hand lay standard

EXPLANATORY NOTES:

- (1) "Diameter Range" indicates the size of conductors that utilize the same tie.
- (2) "Nominal Conductor Size" indicates only a few conductors that have outside diameters within the ranges listed.
- (3) Since all spool insulators do not have neck dimensions suitable for application of the Spool Tie, consult the Insulator Manufacturer's List on the last page in this section.
- (4) AWAC is a registered trademark of the Copperweld Co.

Spool Tie

For use on:

**ACSR, Compacted ACSR,
Aluminum Alloy , ACAR
All-Aluminum, AWAC®
Compacted All-Aluminum**

Spool Insulator

ANSI 53-1

ANSI 53-2

1-3/4" Diameter

ANSI 53-3

Catalog Number	Diameter Range (Inches)		Nominal Conductor Size		Units Per Carton	Wt./ Lbs.	Applied Length (Inches)	Color Code
	Min.	Max.	Bare Conductor	Plastic Jacketed Conductor				
SPL-1356-P	.406	.459	2/0, 7W All Alum. 2/0, 6/1 2/0, 7W Alum. Alloy	#2, 6/1, 3/64s #2, 7W, 4/64s #1, 7W, 4/64s	100	28	28	Blue
SPL-1357-P	.460	.520	3/0, 7W All Alum. 3/0, 6/1 3/0, 7W Alum. Alloy	#4, 7W, 8/64s #1, 6/1, 4/64s #1, 7W-19W, 5/64s 1/0, 7W, 4/64s	100	32	31	Orange
SPL-1358-P	.521	.588	4/0, 7W All Alum. 4/0, 6/1 4/0, 7W Alum. Alloy	1/0, 6/1, 4/64s 1/0, 7W, 5/64s 2/0, 7W, 4/64s 1/0, 6/1, 5/64s	50	18	32	Red
SPL-1359-P	.589	.665	266.8, 37W All Alum. 266.8, 18/1	3/0, 7W-19W, 4/64s 3/0, 6/1, 4/64s 4/0, 7W 19W, 4/64s 3/0, 6/1, 5/64s	50	19	23	Purple
SPL-1360-P	.666	.755	336.4, 18/1 336.4, 19W All Alum. 397.5, 19W All Alum. 400, 19W, 37W All Alum.	4/0, 7W, 5/64s 3/0, 6/1, 6/64s 4/0, 6/1, 5/64s 266.8, 19W, 5/64s	50	24	25	Brown
SPL-1361-P	.756	.858	477, 19W, 37W All Alum. 477, 18/1, 24/7, 26/7, 556.5, 19W All Alum.	266.8, 18/1, 5/64s 336.4, 19W, 4/64s 336.4, 37W, 6/64s	50	25	26	Red
SPL-1362-P	.859	.968	556.5, 26/7 636, 18/1 700, 37W, 61W All Alum.	350, 37W, 6/64s 336.4, 19W, 8/64s 450, 37W, 5/64s 477, 37W, 5/64s	50	26	28	Blue

Right-hand lay standard

EXPLANATORY NOTES:

- (1) "Diameter Range" indicates the size of conductors that utilize the same tie.
- (2) "Nominal Conductor Size" indicates only a few conductors that have outside diameters within the ranges listed.
- (3) Since all spool insulators do not have neck dimensions suitable for application of the Spool Tie, consult the Insulator Manufacturer's List on the last page in this section.
- (4) AWAC is a registered trademark of the Copperweld Co.



Spool Tie

INSULATOR MANUFACTURER LIST:

Any given *Spool Tie* appearing in our catalog can be used interchangeably with any insulator of the same corresponding neck diameter appearing on this list. The diagramed neck dimensions, important to *Spool Ties*, are part of the ANSI Standard C-29.3 Specification.

ANSI 53-1

ANSI 53-2

ANSI 53-3

1-3/4" Neck Diameter

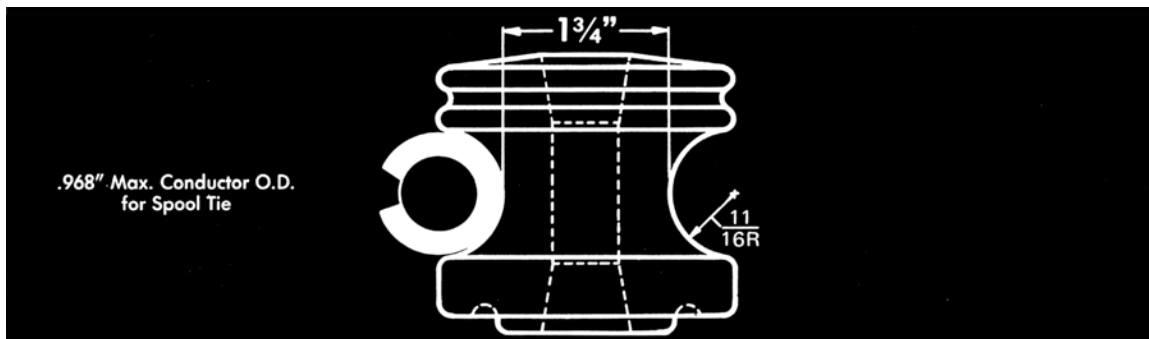

Chance	Joslyn	L.M.	Locke (G.E.)	Knox	Ohio Brass	Oliver	Utilities Serv.	ITE-Victor
C-909-0032	J-101 J-151	DE 453 DE 453 DE 453	#355	#310-W #310-D	#36361 #36368	#2000	#204 #204W #205 #205W	#2012

*Note: **ANSI 53-1 and 53-3 spool insulators** with 1-3/4" neck diameter will accept only a maximum conductor of .563" with a Spool Tie.*